

Introducción

♩ = 75

Juan Barrena

The musical score is written for guitar in G major (one sharp) and 4/4 time. It consists of four systems of two staves each. The upper staff shows the guitar chord progression with chord diagrams and fret numbers. The lower staff shows a melodic line with fingerings and accents.

System 1 (Measures 1-4):
Chords: Em (0), D (2), Cmaj7 (0), Bm7 (x).
Melody: m i m i (measures 1-2), then a sequence of eighth notes (measures 3-4).

System 2 (Measures 5-8):
Chords: Bb6 (5), Am7 (5), G (5), D/F# (5), Em (5), Ebmaj7 (5).
Melody: A sequence of eighth notes with fingerings 1, 2, 3, 4.

System 3 (Measures 9-14):
Chords: Cm7 (9), F (9), G (9), G (9), Em (9), D (9).
Melody: A sequence of eighth notes with fingerings 1, 2, 3, 2, 3, 0, 0.

System 4 (Measures 15-20):
Chords: Cmaj7 (15), Bm7 (15), Bb6 (15), Am7 (15), G (15), D/F# (15).
Chords: Em (20), Ebmaj7 (20, 3fr), Cm7 (20), D7 (20), G (20), D7 (20), G (20), C (20).
Melody: A sequence of eighth notes with fingerings 1, 2, 3, 2, 3, 0, 1.

25

G F G D G G C G

29

F G D G G Am7

33

G/B C Bm Am G F D/F# G Em

38

D Cmaj7 Bm7 Bb6 Am7

43

G D/F# Em Ebmaj7 Cm7 D7 G

Introducción

(Melodía 2)

Juan Barrena

♩ = 75

8^{va}- G D⁷ G C G F G D

21

21

27 G G C G F G D G G Am⁷

33 G/B C Bm Am G F D/F# G

44 Em E^bmaj⁷ Cm⁷ D⁷ G

Introducción

(Melodía 3)

♩ = 75

Juan Barrena

Coro

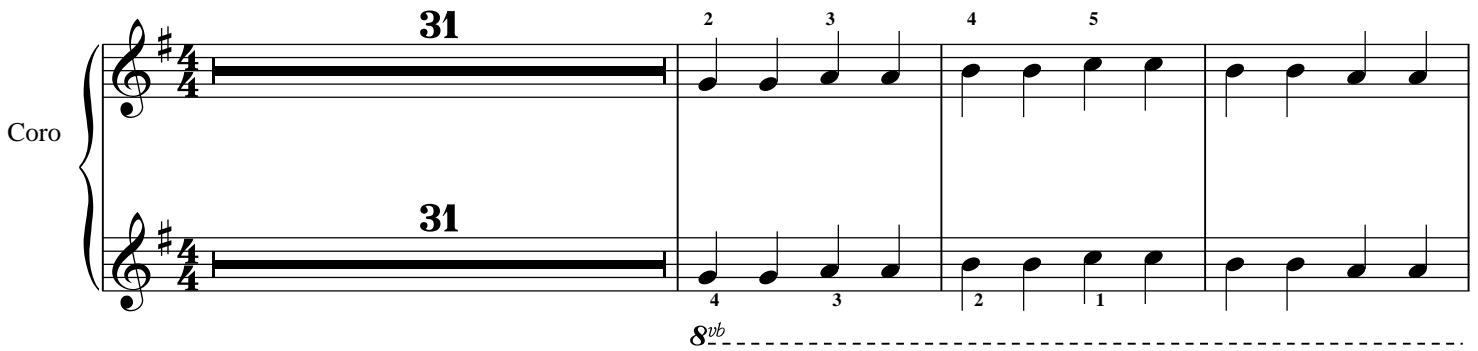

31

2 3 4 5

31

4 3 2 1

8^{vb}

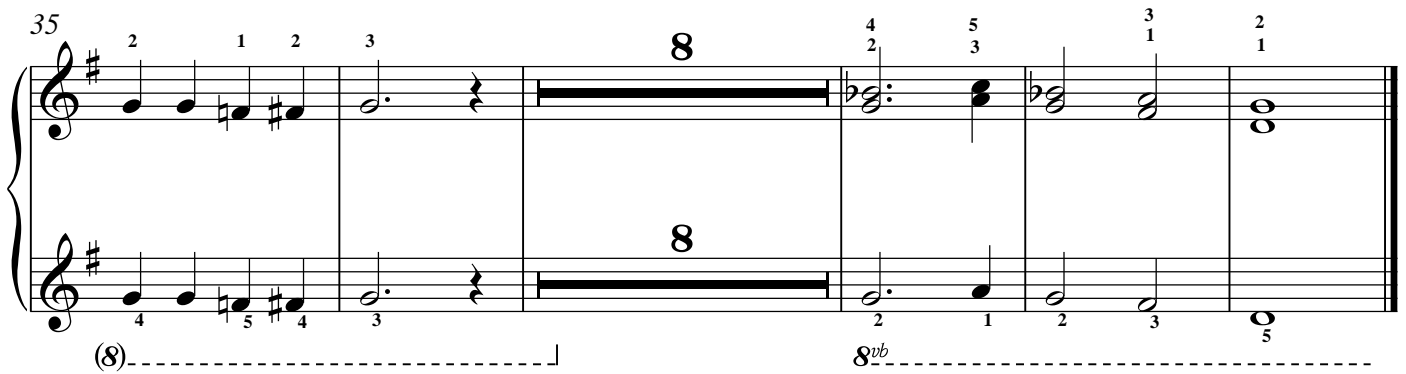

35

2 1 2 3

8

4 5 3 1 2

8

8

8

8^{vb}

Introducción

Juan Barrena

♩=75

Acordeón
o Melodica

Em¹ D Cmaj⁷ Bm⁷ B^b6 Am⁷

G D/F# Em Eb Cm F G

Em D Cmaj⁷ Bm⁷ B^b6 Am⁷

G D/F# Em Eb Cm D G D G C

G F G D G G C G F G

D G G Am G/B C Bm Am

G F D/F# G Em D Cmaj⁷ Bm⁷

B^b6 Am⁷ G D/F#

Em Eb Cm D G

Introducción

(Progresión Armónica)

Juan Barrena

Teclado
Cuerdas

The musical score is written for guitar in 4/4 time, featuring a key signature of one sharp (F#). It consists of six systems of music, each with a treble and bass staff. The chords and their corresponding bass line notes are as follows:

- System 1 (Measures 1-4):** Em (1), D (2), C (1), Bm (2).
- System 2 (Measures 5-8):** Bb6 (3), Am (4), G (1), D/F# (2), Em (1).
- System 3 (Measures 9-12):** Eb (3), Cm (5), F (2), G (1), G (1).
- System 4 (Measures 13-16):** Em (1), D (2), C (1), Bm (2).
- System 5 (Measures 17-20):** Bb6 (3), Am (4), G (1), D/F# (2), Em (1).
- System 6 (Measures 21-24):** Eb (3), Cm (5), D (4), G (1), D (4), G (1), C (5).

25 G F G D G

1 2 1 4 1

28 G C G F G D G

1 5 1 2 1 4 1

32 G Am G/B C Bm Am G F D/F# G

5 4 3 2 3 4 1 ③ 2 1

37 Em D C Bm Bb6

1 2 ① 2 3

42 Am G D/F# Em Eb Cm D G

4 1 2 ① 3 5 4 1